

Water Quality Check Kit for Emergency Situations

Andrey Gavrilov

CS 488 Senior Capstone

Professor: Charlie Peck

Abstract

Water is a scarce resource and the dearth of effective tools to convert other types of liquid into fresh water makes us even more vulnerable to risks caused from this scarcity. The situation becomes critical after disasters strike and there is no planned way to provide emergency aid to the victims and take them out of the situation immediately, that is why we send them tools that could help them survive. In this survival kit, one of the most important components would be a mechanism via which they can extract water from the surroundings. Filters are very useful and they serve very well, but sometimes they tend to defect and not work according to the specifications provided by the manufacturer. My goal in this research is to explore a technique and develop a device that is able to detect whether the filter is working properly. Such devices do exist but they cost in thousands of dollars, whereas the device that I am working on would cost less than \$200.

Table of Contents

1.0 Introduction

1.1 Natural disasters

1.2 Developing countries

2.0 Project

2.1 Proposal

2.2 The Technology

2.2-1 Choice of platform (Galileo vs Arduino)

2.2-2 Conductivity sensor (how it works)

2.2-3 Software

2.2-4 Colors vs Words

2.2-5 Packaging (3D printing and box engineering)

2.3 Where it can be used?

2.4 Towards Cheaper, Smaller, Better

3.0 Conclusion & Results

1.0 Introduction

Water is a precious resource that is a crucial constituent of the fluids of living things on our planet. Scientists have calculated that of the 97.5% of the total water mass on our planet, of the remaining freshwater, only 1% is considered to be usable and potable [1]. However, even that one percent is not evenly distributed [2]. Nowadays the world is in danger of a global water quality crisis. The main reasons that have led to this situation are rapid population growth, urbanization, industrialization, and expanding food production. All these factors put pressure on the sustainability of water resources [1]. The good news is that all of these factors show their effects only in the long term and can be monitored by people, whereas natural hazards can be a bigger danger since they require immediate response [3].

1.1 *Natural disasters* are now carrying more danger than ever before [4]. Between 1991 and 2000, 665,000 people died in 2,557 natural disasters, of which 90% were water-related events. 97% of the victims were from developing countries [5]. Nevertheless, united organizations such as Red Cross and UNICEF are working hard on the new methods of rescuing people and developing a new technology in order to minimize the loss of human life.

1.2 *Developing countries* have been under water crisis for a long time already, but the issue has not disappeared, despite the measures taken to ameliorate and prevent it, instead it has become worse as the countries develop. In 2012 the Millennium Development Goals Report showed that 783 million people, which is equivalent to 11% of the global population, did not have access to clean water. Approximately 2.5 billion people did not have access to standard sanitation and the numbers keep growing [9]. Annually, about 3 million people die from water-related diseases in developing countries, even though most of these illnesses and deaths could be prevented by conducting simple, inexpensive water quality tests [8, 10].

In this paper I will discuss the features and capabilities of the Water Quality Kit and how it can play a significant role in saving people's lives in the emergency situations. I explain the importance and necessity of such item and I explore the possibilities of making this an affordable and useful item for the Disaster Response teams. Later in the paper I calculate the costs of the device and then reasons why I chose these specific components to complete the project.

2.0 Project

Nowadays, the topic of Disaster Preparation and Response is a crucial one because humans are not yet able to predict and respond to the natural disasters as well as we wish we could. Most of the time organizations such as UNISDR (The United Nations Office for Disaster Risk Reduction), Red Cross and local forces make attempts to rescue people from the epicenter of the disasters. This is not always possible because some citizens do not abide by the directives of the organizations and stay in their homes. In other cases the technology to transport victims out of the endangered zone does not exist. In such cases the only useful solution would be to send a survival kit that would include the basic and necessary items to keep someone alive until help arrives. Having access to clean water has been deemed necessary by every survival kit that has been devised. Since it is difficult to continuously supply people with filtered bottled water, often rescuing organizations will send filters to the people so they can access clean water at all times.

Filters are specially designed to purify water without using any chemicals. One of the revolutionary filters in terms of price and performance that we can find today in the market is the LifeStraw. This filter claims to make water that is infected with bacteria and protozoa safe to drink. Another advantage is that it is really light and requires no electricity [7]. This is a good water filter that can save a lot of lives from drinking polluted water, but I have some concerns regarding the information that people have about the condition of the filter. No system

operates in full capacity at all times, that is why after several uses every filter loses its capability to efficiently clean all the materials from water.

2.1 Proposal

Filters, in my opinion, give you a blind hope that the water you drink is clean. Filters, just like any other technology can break or simply expire and not perform according to the factories standards that it was supposed to have. That means that people who receive filters in the emergency situation might have a naive confidence drinking from the filter without having an opportunity to check if it works the way it is supposed to.

It is one thing to hope that the filter works, but it is a lot better to have basic information about the water if it is good to drink or not. After doing some research I found that by using a conductivity sensor, we are able to detect and measure the amount of ions in water. Once we note the concentration of ions in water before filtration, we can take another test and find out if that number has changed. Theoretically, if the filter is working properly, it should clean 99.9% of waterborne bacteria and viruses, and reduce the number of ions. Knowing both variables is enough information to be able to make a calculated guess about the conditions of the filter, and of course the quality of the water.

2.2 The technology

To create this device, it was necessary to do the research of an unfamiliar field. Part of this included talking to professors from the Chemistry and Biology departments. This project required working the multiple tasks. It was an important decision to make what platform to choose when it came to conductivity sensor. I had to write software and engineer a 3D printed box to contain the prototype. In this paper, I describe the steps followed and the challenges I faced while working to turn this project into reality.

2.2-1 Choice of platform (Galileo vs Arduino)

During the 2014 spring semester I have been working with a couple of students on the Galileo platform. I learned a lot about it and when I came back this semester to do this project, Galileo was my first choice. Although it could work reliably for a short period of time, I had to spend a lot of time debugging it once or twice a week. Also, since Galileo was a new platform on the market it did not have much documentation which also slowed down the project. As I searched for other alternatives, Arduino UNO was the best option to substitute Galileo. UNO had the same functionalities, but it is smaller, easier to use, and there is a lot more documentation available on how to work with it.

2.2-2 Conductivity Sensor (How it works)

At the beginning, when I first started thinking about the project I had one main question to address, how to tell if the water is good to drink? My first thoughts were to find what are the most important and general criteria for water, so that I could find a way to measure them and tell if the water was clean. It turned out that water has a very complicated structure and that the usual device scientists use to analyze the quality of water costs over \$10,000. My goal was to make a cheap and reliable device that would not cost anywhere close to that price. After doing more research and meeting with chemists once more, I found an alternative solution – the conductivity sensor.

When I started advancing into the project and I came to the point where I needed to buy the conductivity sensor, I realized that there was not only one value of conductivity that I had to take into account. The accuracy of the conductivity values depend on the technique used to measure it, and so were the probes used as described below:

$K = 0.1$ accurate reading range $0.07 \mu\text{s}$ to $50,000 \mu\text{s}$

$K = 1.0$ accurate reading range $5 \mu\text{s}$ to $200,000+$ μs

$K = 10$ accurate reading range $10 \mu\text{s}$ to 1 S [11].

For this project I chose to buy a probe with $K=0.1$. When the water is filtered the number of ions would drop significantly so choosing $K=0.1$ probe was the right choice because the probes with a different range would not be able to detect the low amount of ions present in the water after filtration.

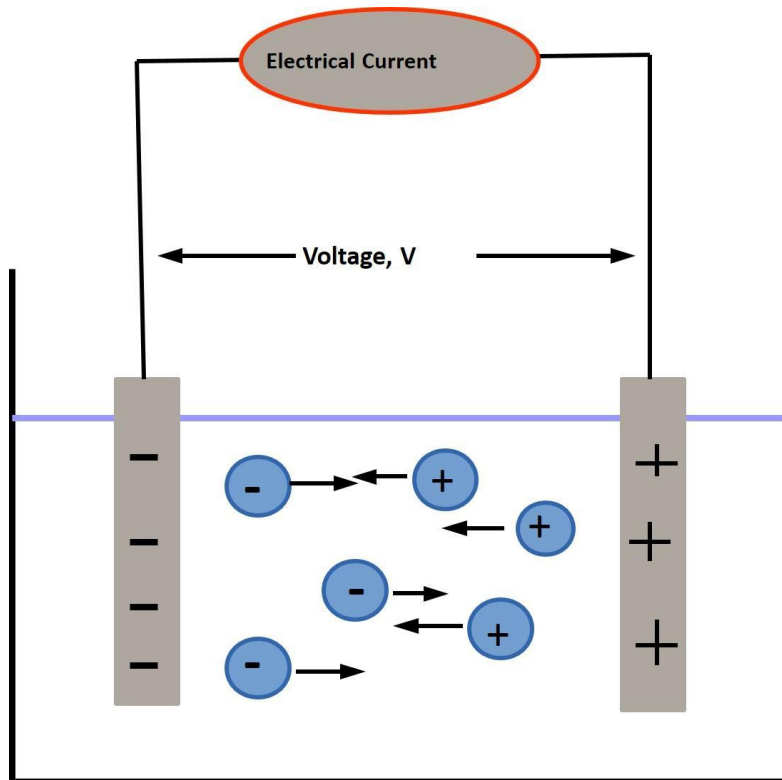

Figure #1. Diagram of conductivity meter and illustration how ions move in the water

Conductivity is a measure of the electrical current in the solution such as water. The electrical current in water is made by inorganic dissolved solids - ions that carry a negative and positive charge [14]. The more ions are in the water the higher the conductivity of water. A good example of this occurrence would be sea water, which has a high conductivity, whereas filtered or deionized water will have a low conductivity.

2.2-3 Software

- 1) void function "pars data"
- 2) declare variable for conductivity "cond" = atoi(EC); // using atoi to convert the char into integers
- 3) Print the value of "EC" - conductivity
- 4) Since I already converted the char to integers (step 1), we can use that value now
- 5) if cond > 1000 Now take the rough max value of ions that water can have after filtration
- 6) If it is greater than 1000 then turn the red led on and green led off, indicating that the water is not filtered

7) else switch the green led ON and red OFF , indicating that the number of ions have changed and the water is filtered

Figure#2. This is a source code of the function `void pars_data()` , the function that is comparing the values of the EC sensor

Above, on the Figure #2 you can see part of the software that I wrote for this project. In the function `pars_data`, I am first converting the default output from the conductivity sensor, converting characters to integers. Then I take that value of ions present and compare it to the maximum value of ions that water could have after filtration. The expectation is that it will be less than the maximum value, and if it is, then the LED on the device will turn ON with a green color, signaling the user that the filter is working properly and the water is good to drink.

Whereas if the initial value of ions would stay the same or is higher than the acceptable value , the device will display the red light, warning the user that for some reason the filter is not performing the way it is supposed to.

2.2-4 Color vs Words.

One of the things that I was debating about was whether I should be using numbers, words or colors to inform the user about the outcome. It turns out that it makes more sense to be descriptive and provide more information when you are working in the lab, whereas in the critical emergency situations it is more important to keep information as short and clear as possible. When creating a product like this, it is important to consider that the user may not know English, German, French or any other language that would be the default on the device. Therefore I made a decision to use red and green lights to inform a user about the water quality.

2.2-5 Packaging (3D printing and box engineering)

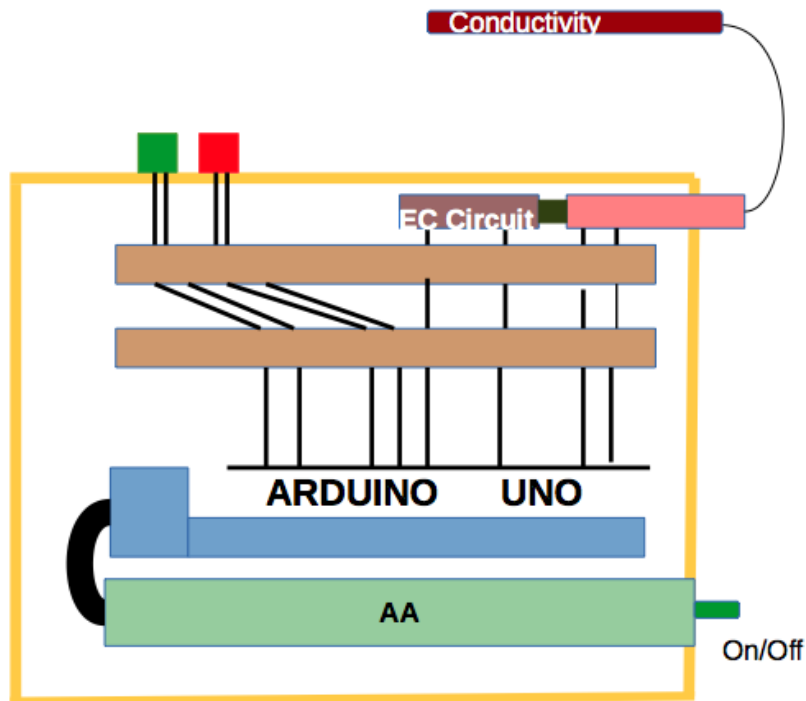

Figure #3. Sectional view of the kit

Nowadays, as technology progresses 3D printing is becoming more popular than ever before. 3D printing is a process of printing a three-dimensional project using manufacturing material such as plastic [15]. Figure 3

represents the sectional view of my device. I tried to come up with a way to use less space by making the device smaller while at the same time making sure that it is secure from any unintentional force that could damage it.

Item	Price (\$)
Arduino UNO	15
Atlas Electrical Conductivity Kit	175
Battery for Arduino	7
Wire, LED, 3D printing	3
Total:	200

Figure #4. Price list of all items for Water Quality Check Kit

2.3 Where can it be used?

Water Quality Check Kit is designed to be used in combination with a filter that is a part of the “Survival Kit” delivered to people who are in tandem of not having access to clean water. One example could be the rescuing process after natural disasters such as flooding, where a lot of people are not able to leave their house immediately and have to wait for help. The entity in charge of rescuing victims of natural disasters will then make a decision and choose between those who need immediate help and those who will receive a “Survival Kit” and have to wait for help.

I believe that this product can be very practical and useful in developing countries. There are multiple projects out there where organizations that operate under a humanitarian entrepreneurship business model. One example is the Vestergaard Frandsen (VF) and the LifeStraw partnership which led to the development of a “LifeStraw Family Filter” for the purpose of helping families without access to a clean source of water in developing countries[12]. Just one Water Quality Check Kit is enough to be able to keep track of the multiple filters.

2.3 Towards cheaper, smaller, better

Nowadays creating a working prototype, even if it is a revolutionary idea, is not enough. If you are interested in getting attention from other people, scientists or investors, you must come up with a way to make your device better, cheaper and smaller than already existing solutions to the problem you are solving [13].

When I was looking at different platforms that could work for this project one of the criteria that I was looking at was the size of the device. That is why when the time came to make a decision to stay with Galileo or get Arduino UNO, I went with UNO.

3.0 Results



(Figure # 5. Graph of the output from the serial monitor)

As seen in Figure #5, the conductivity sensor measures the number of ions in two probes. “Blue probe” represents the tap, unfiltered water, whereas “Red probe” is filtered water. The graph shows a big contrast between the two probes. That means that the sensor can easily detect if the water was filtered and if the filter is working the way it is supposed to.

Scalability

The objective goal in the future would be to be able to produce not just one, but potentially hundreds and thousands of identical devices. In other words, to start a mass production.

The first step would be to find a company or organization who would be interested in investing in this project. Previously, in this paper in the section “Towards cheaper, smaller, better” I already talked about what it takes to get attention on the product.

Assume that my kit got noted from the Red Cross organization, as they are making their decision to include my device on their “Survival Kit”. It is not an easy decision, because this would mean spreading these devices around the world, and they must be confident that the cost to make it is reasonable and that it is easy to replicate.

It is crucial to keep all of the documentation about the device. Moreover, it is important to do it in a way that if someone would want to repeat my project, with my documentation they could do it easily. Although, I have made a price list of how much it would cost to build my kit, in the real world when the product starts to be manufactured the cost to make it drops significantly. For example, in order to build my kit, I had to buy a conductivity sensor from the Atlas Scientific for \$ 190. Now, if I wanted to buy not just one, but with 20 sensors the cost would drop to \$175 each. It may not look like a big change, but by buying 20 units in bulk will

reduce costs by \$300. I have a reason to believe that Atlas would give even bigger discount if larger quantities were bought. This is a good example of how the cost starts to go down when it comes to manufacturing. This applies to other items in my list such as the cost of Arduino, batteries LEDs and ect...

Conclusion

After completing various tests on the device by changing the conductivity of the water, the Water Quality Check Kit for Emergency Situations has proved to work accurately and consistently without showing any signs of errors. Although the kit has passed the lab tests, it still needs to be tested in the field to confirm its capability. I believe that the design of the device can be improved inside (wiring) as well as outside (outlook) to make it simpler and user-friendly. One of my suggestions for the device would be to develop an app that would be linked with the kit to tell the user more detailed information about the water. However, this could increase the price of the device and make it less affordable. It could also potentially make it more complicated to get the information quickly and easily. Overall, this device has a potential for a development and hopefully one day becomes an item on the “Survival Kit,” so that one more person could be confident that the water he/she is drinking is clean and one more life could be saved.

Acknowledgement:

I would like to extend my gratitude to the people who helped and supported me in successfully completing this project. I would like to thank my professor and supervisor Mr. Charles Peck for the attention and feedback I received on the project. I am especially grateful to Professor Mike Deibel and Professor Corinne Deibel for their assistance in helping me understand more on the criteria needed to determine the water quality. His assistance was instrumental to the completion of the project.

Reference

- [1] Corcoran, Emily. 2010. "Sick Water?" .UNEP/GRID-Arendal. 26 Sep. 2014. Web < http://www.unep.org/pdf/SickWater_screen.pdf >
- [2] *Progress on Sanitation and Drinking Water 2010 Update*. Geneva: World Health Organization, 2010. UNICEF. Web. <<http://www.unicef.org/eapro/JMP-2010Final.pdf>>.
- [3] "Disability, Natural Disasters and Emergency Situations." UN. WCDRR World Conference on Disaster Risk Reduction, n.d. Web. <<http://www.un.org/2Fdisabilities%2Fdefault.asp%3Fid%3D1546>>.
- [4] 2006. "The Challenge in Disaster Reduction for the Water and Sanitation Sector: Improving Quality of Life by Reducing Vulnerabilities". Washington, D.C.: Pan American Health Organization. 26 Sep. 2014 Web. < http://esa.un.org/iys/docs/san_lib_docs/DesafioDelAgua_Eng-intro.pdf >
- [5] "UN-water Global Annual Assessment of Sanitation and Drinking-water" 2008 Pilot Report: Testing a New Reporting Approach. Geneva, Switzerland: World Health Organization, 2008. Web.
- [6] "Safer Water, Better Health: Costs, benefits, and sustainability of interventions to protect" 2008, World Health Organization (WHO). (2008).
- [7] "LifeStraw® Family 1.0." *Buy LifeStraw® Family Online | LifeStraw® Family Water Filter Specifications*. N.p., n.d. Web. 04 Nov. 2014. <<http://www.buylifestraw.com/products/family>>.
- [8] "WHO World Water Day Report." *WHO World Water Day Report*. N.p., n.d. Web. 04 Nov. 2014. <http://www.who.int/water_sanitation_health/takingcharge.html>.
- [9] "Global Issues at the United Nations." *UN News Center*. UN, n.d. Web. 02 Nov. 2014. <<http://www.un.org/en/globalissues/water/>>.
- [10] "Water in a Changing World." N.p.: UNESCO, 2009. The United Nations Educational. 2009
- [11] Tm. "Atlas Scientific." *EZO Class Embedded Electrical Conductivity Circuit* (n.d.): n. pag. 2013. Web. <http://www.atlas-scientific.com/_files/_datasheets/_circuit/EC_EZO_Datasheet.pdf>.
- [12] McCutcheon, Stacey, and Lyn Denend. *LIFESTRAW CARBON FOR WATER: Sustainable Funding for a Public Health Intervention THE PROBLEM/SOLUTION SPACE* (n.d.): n. pag. 2012. Web. <<http://www.gsb.stanford.edu/sites/default/files/documents/LifeStraw-SustainableFunding.pdf>>.
- [13] "Better, Cheaper, Faster, Smaller..." *Pitt Innovator LIBRARY* (n.d.): n. pag. University of Pittsburgh, 2012. Web. <<http://www.innovation.pitt.edu/sites/default/files/Value%20Proposition%20Basics.pdf>>.
- [14] "Water: Monitoring & Assessment 5.9 Conductivity." *EPA*. N.p., 2012. Web. <<http://water.epa.gov/type/rsl/monitoring/vms59.cfm>>.
- [15] Excell, Jon, and Stuart Nathan. "The Rise of Additive Manufacturing." *Engineering News & Engineering Jobs*. The ENGINEER, 2010. Web. <<http://www.theengineer.co.uk/in-depth/the-big-story/the-rise-of-additive-manufacturing/1002560.article>>.